

# BTEC Level 1/2 ICT

## Unit 6: Creating Digital Graphics

### Assignment: Researching and Designing Digital Graphics

Learner Name: Nuuh Arale \ Learner ID Number: 239005

## TASK 1 – Investigating Two Different Graphic Products (P1, M1, D1)

### 1.1 Graphic Product 1 – Bitmap

Product Type: Travel Magazine Cover

Product Source (URL):

<https://magsdirect.co.uk/magazine/conde-nast-traveller-magazine-april-2025/>



## **Intended Purpose:**

The purpose of this magazine cover is to attract readers and encourage them to purchase the magazine by using a high quality and an award-winning photograph.

## **Features and Components (P1)**

### **Layout / Composition:**

The magazine uses a layered composition. The masthead “Condé Nast Traveler” is positioned at the top and partially overlaps the background landscape, creating depth.

### **Use of Color:**

Natural greens and blues are used to represent the environment.

### **Size and Position of Elements:**

The word “THAILAND” is displayed in a large font in the center of the page to highlight the main feature.

### **Image Type:**

This is a bitmap image because it is a photograph picture.

### **File Format & File Size:**

The image would be saved as a JPG or TIFF file at 300dpi for printing. Bitmap images of this quality are big (5-10MB).

## **Product Review – Fit for Purpose (M1)**

This product is fit for purpose because the high light bitmap image creates realism and escapism.

## **Strengths and Weaknesses (D1)**

### **Strengths:**

A strong perspective makes the viewer feel as if they are part of the scene. Some white text is placed over light background areas.

## **1.2 Graphic Product 2 – Vector**

**Product Type:** IKEA Furniture Assembly Manual

### **Product Source:**

<https://www.gebruikershandleiding.com/Ikea-Hemnes-garderobekast/preview-handleiding-51500.html?page=0008>

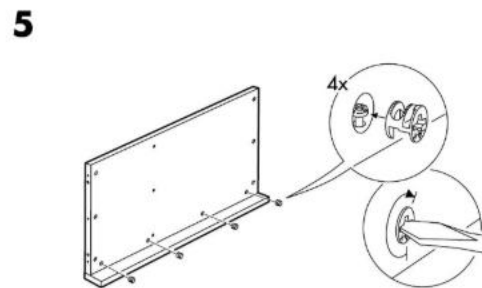
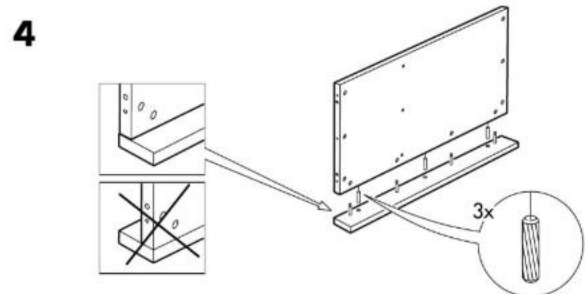
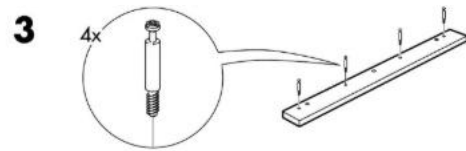
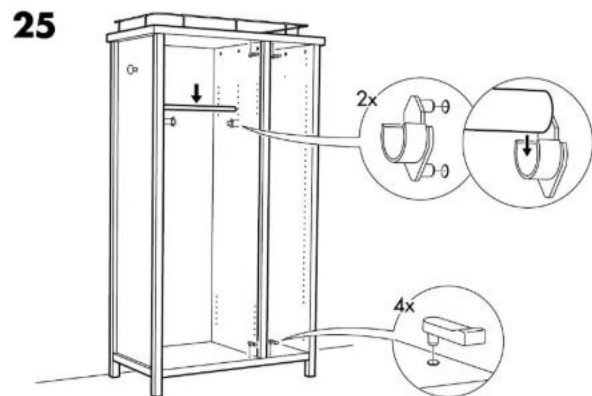
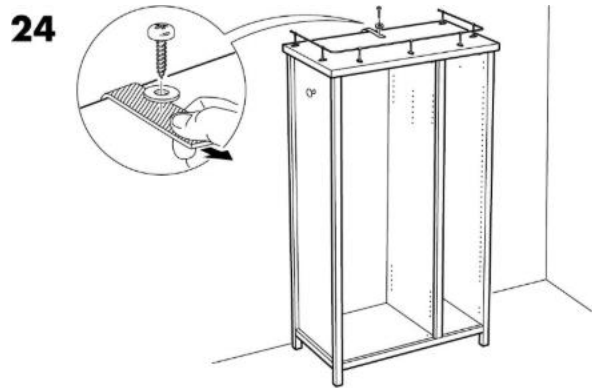

## **Intended Purpose & Target Audience (P1)**

The purpose of this graphic is to inform and educate users on how to assemble IKEA furniture correctly by using visual instructions instead of text. It's meant for adults and construction workers.

## **Features and Components (P1)**

### **Layout / Composition**

The guide uses a numbered step by step layout.

### **Use of Color**

A black and white color scheme is used to keep focus on shape and form while reducing printing costs.

### **Size and Position of Elements**

Large numbers show the step order clearly.

### **Image Type**

This is a vector graphic.

### **Advantages:**

Can be zoomed in without pixelation.

### **Disadvantages:**

It isn't a colorful image or family friendly

### **File Format & Size**

It's saved as a PDF or SVG. File size is small, allowing faster downloads.

### **Product Review – Fit for Purpose (M1)**

This product fits criteria. The use of symbols such as the “X” shows what not to do, and it helps to prevent mistakes.

### **Strengths and Weaknesses (D1)**

#### **Strengths:**

Bold lines separate furniture parts from tools, to show clarity.

#### **Weaknesses:**

some physical details like material texture may be hard to identify.

## **TASK 2 – Designing Graphic Products (P2, P3, M2, D2)**

### **2.1 User Guide – Vector Graphic (P2)**

#### **Purpose (P2)**

To educate new smartphone owners about their device.

#### **Target Audience (P2)**

Anyone aged 16+ who has purchased a smartphone.

#### **Requirements from the Brief (P3)**

- Wireframe smartphone illustration
- Labels for big Camera, Laser Autofocus, and S Pen Slot
- Accurate proportions

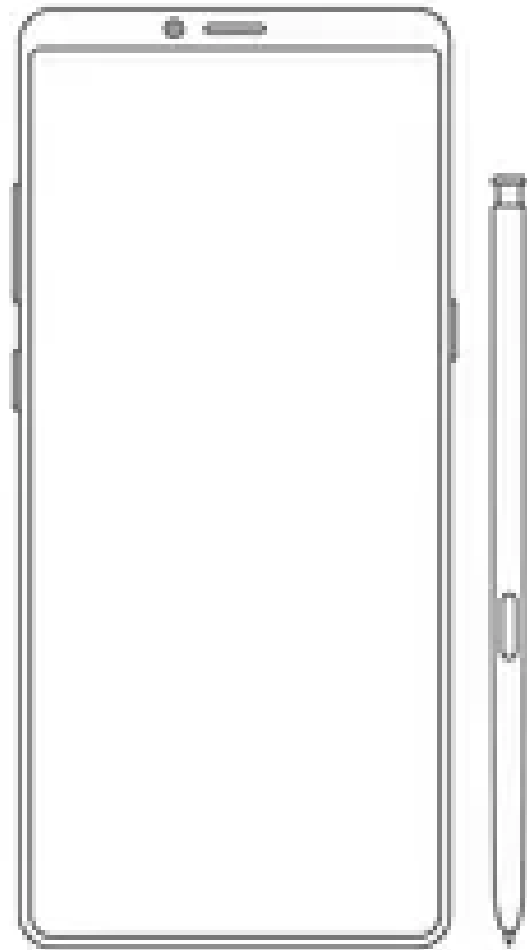

### **Final Design Justification (D2)**

The design uses sharp vector lines to create a professional appearance. Labels are placed outside the phone with clear arrows to improve readability. All features listed in the brief are clearly labeled. Realistically drawing the phone using a bitmap allows me to create realistic lighting and gradients.

## 2.2 Asset Annotations (P3)

Asset	Original / Ready-made	Source	File Type	Resolution
Smartphone Line Drawing	Ready-made	Samsung Support	SVG	Vector
Feature Labels	Original	MS Word	N/A	N/A
Annotation Arrows	Original	Word / Illustrator	PNG	72dpi
S Pen Illustration	Ready-made	Samsung Brand Toolkit	SVG	Vector

## 2.3 Alternative Design – User Guide (M2)

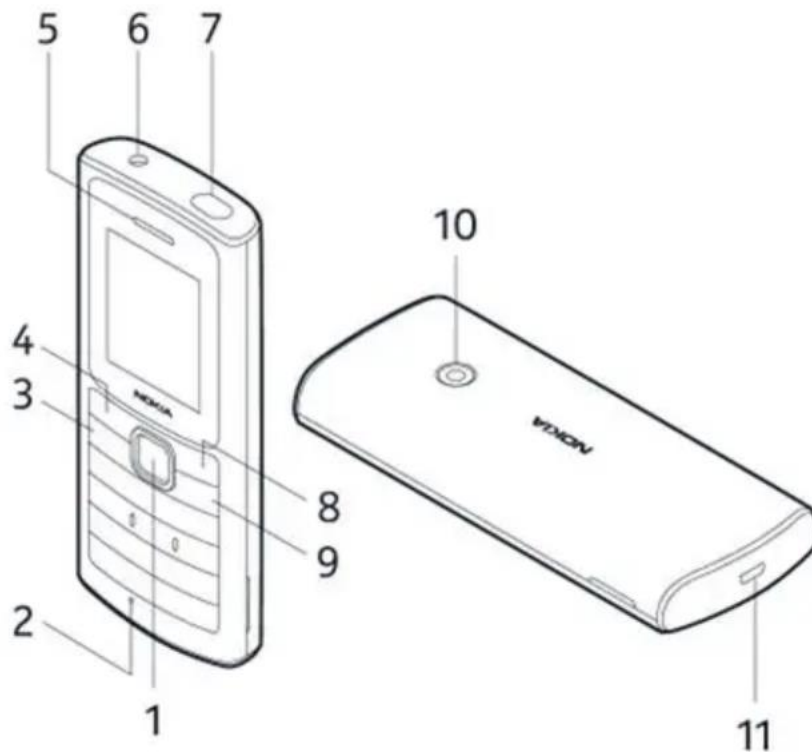

This alternative design used numbered labels instead of text, but the final design was clearer and easier to understand.

## 2.4 Improvements – User Guide (D3)

The before version:

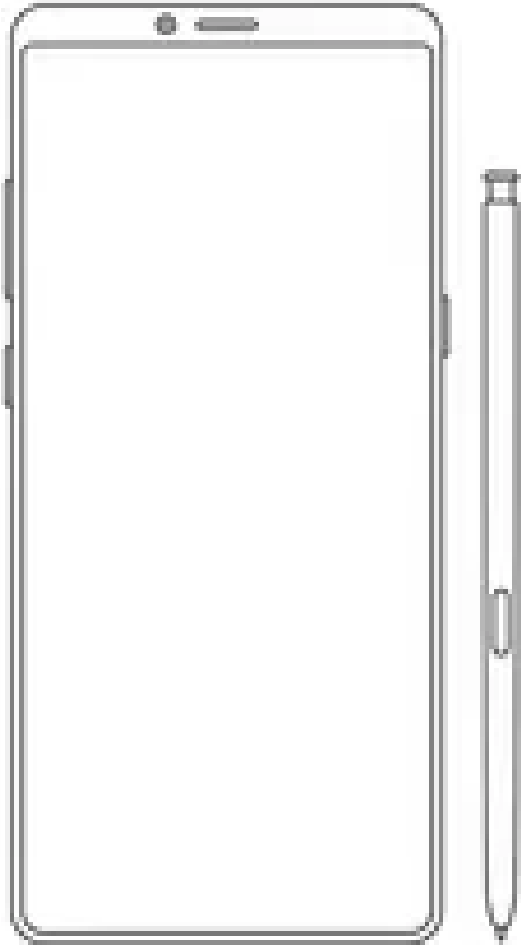

The after version:

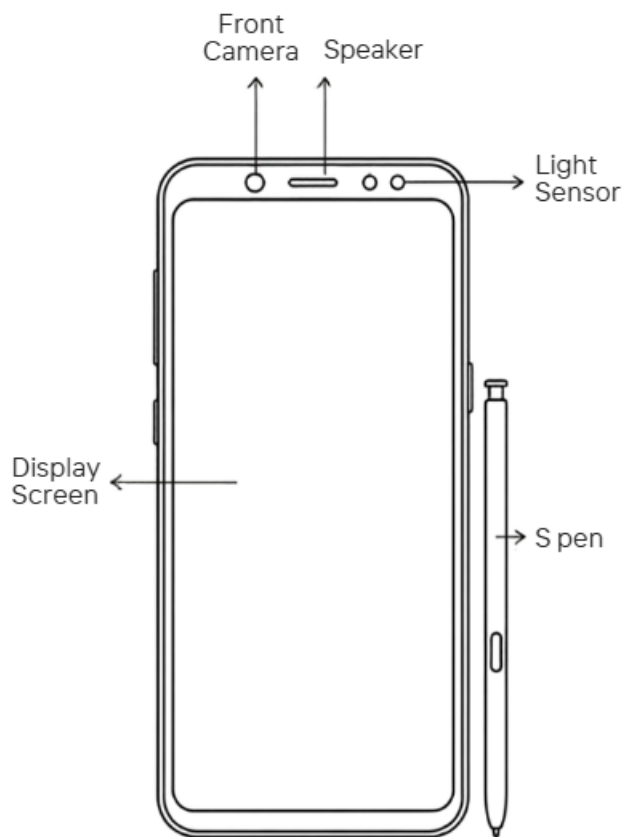

**Summary of Changes:**

The definitive version includes clear labels, straight annotation lines, improved hierarchy, and accurate proportions to ensure the guide is informative and easy to read.

## 2.5 Advert – Bitmap Graphic (P2)

### **Purpose (P2)**

To promote a high-end smartphone and persuade customers to purchase it by showing the phone in use.

### **Target Audience (P2)**

Aged 16–35 who are interested in technology, social media, photography, and mobile gaming.

### **Requirements from the Brief (P3)**

- High resolution bitmap image
- Catchy slogan
- fixed image compression
- The phone is positioned in the center/top to immediately draw attention
- A blurred or glowing background is used to make the phone stand out
- Bright contrast and lighting are used to make the product look premium
- A bold sans-serif font is used for the slogan to improve readability
- The slogan is placed near the top/bottom to catch attention quickly

### **Final Design Justification (D2)**

The bitmap format was chosen to allow realistic lighting, gradients, and shadows. A lifestyle image was used to create emotional connections and appeal to the target audience.

### **Example:**

- Young audiences respond well to lifestyle imagery
- Bright visuals stand out on social media feeds
- Realistic images increase trust in the product

## 2.6 Alternative Advert Design (M2)

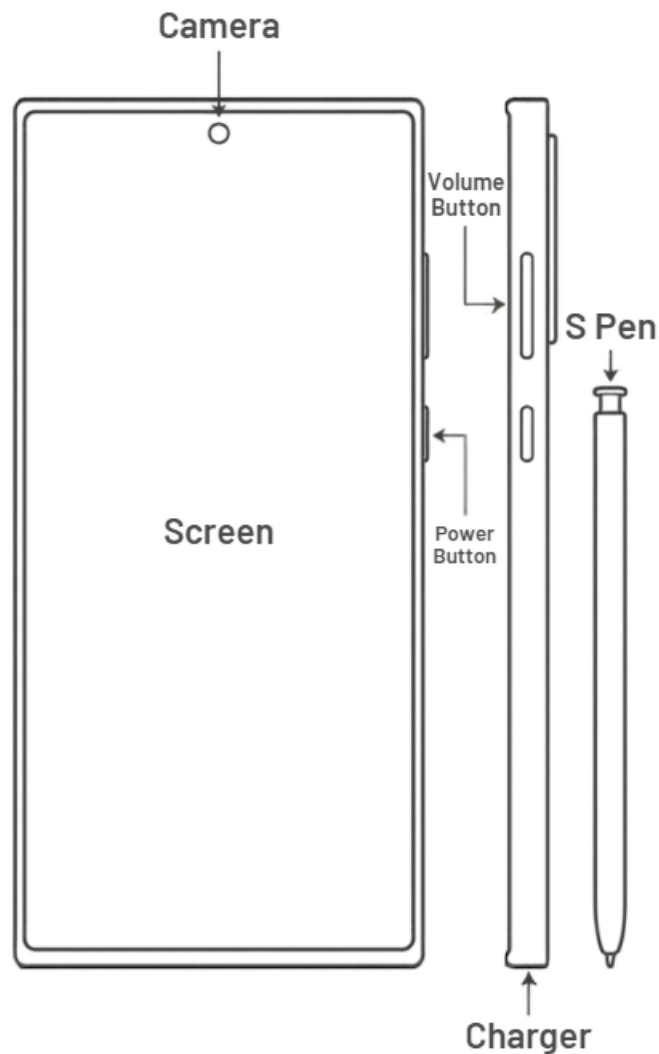

This design was rejected as it lacked emotional impact and did not show the phone in use. Annotations lines are straight allowing for improved proportions. Labels were moved around to improve hierarchy. I added more details to the phone to make it accurate.

## TASK 3 – Create and Test Graphic Products (P4, P5, M3, M4, D3)

### Production details

I used the tool Canva to draw the advert and used ai tools for background shades such as copilot. I have taken an advert idea from googles and followed the same thing step by step and changed the rest fully from my ideas.

### 3.1 Final User Guide (Vector Product)

SAMSUNG



A TOUCH OF  
ELEGANCE

#### **Testing & Feedback Summary (P5 / M4)**

The guide was tested with 5 users within the target audience (aged 16+) and here how they did rate my work:

#### **Positive feedback:**

- 4 users said the guide was easy to follow
- 3 users said the layout looked professional and clean
- 5 users said the labels were clear and understandable
- 

**Negative feedback:**

- 2 users said some labels were slightly too small
- 1 user suggested adding color for better visibility
- Score: Average rating = 9/10

### 3.2 Final Advert (Bitmap Product)



**Before and after comparison**

In my original draft, the advert was much more basic. The Samsung logo was not that visible. You could not see the phone pop out from the background as much

also. The font used for the slogan was too small. My original photo was not well lit. I took my time on making sure my final draft was high quality. I made the Samsung logo brighter. I made my slogan bigger and bolder by using a sanserif font. Instead of placing it in the middle, I moved the phone up to create better balance. I added a glow in the background behind the phone to make it look more dramatic. I made the brightness and shadows POP more on the phone.

- **Summary of changes**

In my original advert it was much basic than my final draft. The Samsung logo was barely noticeable, the phone did not pop out from the background as much, and the slogan was much smaller. I noticed that my original background and overall shot was not well lit. In my final draft, I worked on making my advertisement higher quality. I made the Samsung logo brighter. I made the slogan bigger and bolder by using a San-serif font. I moved the phone up to create a better balance. I worked on the background by making sure there was a glow behind the phone to make it look more dramatic/premium. I increased the contrast and shadows on the phone so that everything pops.

## TASK 4 – Evaluation of Graphic Products

### **Introduction**

In this task, I will evaluate the two final graphic products created for Task 1 – Smartphone Promotion Campaign Brief. Below are the two final products:

- User guideline drawing (vector graphic)
- Smartphone advert (bitmap graphic)

The suitability of each product will be evaluated against the target audience and purpose specified in Task 1. The following areas will be covered in this assessment:

User feedback from Task 3 testing

Any legal and ethical constraints considered during production

How the final products compared to initial designs

The reason for changes made from the design plan

Areas that could be improved in the future

## **Review User Feedback**

Feedback was collected from users during task 3 when the products were tested.

## **User Guide (Vector Graphic)**

Positives:

- Simple and easy to follow
- Not cluttered
- Looks professional

“A user appreciated how easy it was to follow the labels. A simple line drawing style meant I could quickly see what each phone feature was.” Final score 9/10

## **Phone Advert (Bitmap Graphic)**

Positives:

- The phone easily stood out from the background
- Bold slogan that was easy to read
- Looks high quality and professional

“A user preferred version B to the initial draft. The lighting and contrast were better, however what really made the advert was improving the logo size to make it stand out more.”

Both products performed well against the target audience and the purpose they were created for.

## **Legal and Ethical Constraints Considered**

### **Copyright**

As I used some readymade assets to complete both images (smartphone, cables, and logos), I made sure to source them from official sites. Links can be found in task 1 Google Drive > Assets folder.

I have referenced all my assets correctly in the asset table.

## **Ethical**

Nothing in the advert over exaggerates the features of the smartphone.

All images/icons/language used are suitable for all audiences.

Contains no personal or sensitive data.

Meeting these requirements allowed me to produce two safe and professional graphic products.

## **Comparison to Initial Designs and Reasons for Changes Made**

### **User Guide**

Sketch A of how I wanted to label the phone and basic wireframe structure.

Original

Changes made include better label placement, straighter annotation lines for improved proportions, and refined styling. These changes were made to help with clarity and make the guide easier to follow.

### **Phone Advert**

Original

Version B (final product)

Changes were made to lighting/contrast of background to make the phone stand out more. The slogan was made bigger and bolder. I also decided to change the font to sans-serif to make it easier to read. The logo was also increased in size.

## **Resolution, Size and Compression**

I chose to save the advert as a compressed JPEG, which is suitable for both web and print usage.

I chose to save the user guide as a vector image (SVG/PDF). Vector images can be resized without losing quality.

These features will allow both images to be used successfully on their target platform.

## **Suitability for Intended Audience and Purpose (P6)**

### **User Guide**

- Who it is for: Users who own the smartphone (aged 16+)
- What it is for: Educate users on features of their phone in a straightforward way

Accessibility was considered by using vector graphics. I kept labels and overall styling simple to ensure everyone can understand.

### **Smartphone Advert**

- Who it is for: Users interested in technology (aged 16–35)
- What it is for: Sell/buy to persuade viewers

Bitmap was chosen because realistic images are more impactful and can invoke emotion. Bitmap images also allowed me to edit lighting and tones to give a premium quality finish.

### **Areas for Improvement**

If I were to recreate these images again, I would:

Capture feedback from a larger variety of users.

Experiment by adding some color to the user guide.

Create multiple versions of the advert for different uses (website/social media/instore print).

### **Final Thoughts**

Both graphic products meet the needs of their intended audience and fulfill the requirements set out in Task 1. Testing against users allowed me to produce high-quality results that show effective use of both vector and bitmap graphics.

Overall, both of my graphic products meet the needs of their intended audience. They both meet the criteria I set out in Task 1 – Design a Smartphone Promotion Campaign. Testing the products against real users allowed me to produce high-quality results. Proving that I can use both vector and bitmap graphics correctly.